

Product Data Sheet Alura Wall Heating Panel

1. INTENDED USE, SCOPE AND CONDITIONS OF USE

Alura wall heating panels are intended for cladding walls made of concrete, reinforced concrete or bricks and for cladding lightweight partition walls made as frames using metal sections or as studwork, for dry wall construction inside buildings.

The approved heating panel is intended for use in residential or public use premises.

The maximum temperature of the water flowing through the panel's aluminium collector is 80 °C and the maximum working pressure is 12 bar. If the Alura heating panel is to be installed onto a lightweight studwork partition wall, the structure must be covered with a double layer of gypsum boards classified as type A according to the PN-EN 520+A1:2012 standard, 12.5 mm in thickness, as shown in Fig. 3a.

The approved heating panels should be fixed onto a structure of metal sections or a studwork structure, with spacing between centres at 490 ÷ 550 mm. The load-bearing structures for the wall panels should be constructed of cold-bent sections classified as CW 75 and UW 75 according to the PN-EN 14195:2015 standard. The wooden strips should not be smaller than 50 x 40 mm (cross-section). If the heating panels are to be fixed onto a lightweight studwork partition wall, the height of the room should not exceed 3 metres.

When installing the panels onto walls made of concrete, reinforced concrete or bricks,

- use a framework structure constructed of metal sections, with a single layer of gypsum boards classified as type A according to the PN-EN 520+A1:2012 standard, 12.5 mm in thickness, as shown in Fig. 1b;
- use an adhesive that meets the requirements of the PN-EN 14496:2007 standard and apply it onto the whole area of the board (Fig. 1c).

The heating panels should be fixed onto the framework structure (Figs. 1a and 1b) mechanically, using sheet metal screws available on the market and intended for use with gypsum boards.

The adhesive for fixing the approved heating panels must be sufficient to withstand the weight of a product covered with a thin layer of plaster and should be sufficiently elastic, due the possible changes in the dimensions of the panels over time as a result of thermal expandability.

The surface of the panel when fixed onto the structure should be coated with a 1 ÷ 2 mm layer of gypsum plaster that meets the requirements of the PN-EN 13279-1:2009 standard.

The Alura wall heating panels are impact resistant and as such are approved for use in rooms classified as I, II or III according to the ETAG 003 Guideline for European Technical Approvals.

The Alura heating panel should be used in accordance with the technical designs for the building in which they are to be used, in compliance with

- the applicable construction regulations and standards, including (in particular) the Regulation of the Polish Minister of Infrastructure of 12 April 2002 on the technical requirements for buildings and the location of buildings (Dz.U. (Journal of Laws) No.75/2002, item 690, as amended),

Registered:
SOFFIO Sp. z o.o.
ul. Zielona 11
43-502 Czechowice-Dziedzice
POLAND

Correspondence address:
SOFFIO Sp. z o.o.
ul. Juliusza Słowackiego 33
43-502 Czechowice-Dziedzice
POLAND

NIP: 6521725602
REGON: 362482429
KRS: 0000575000

- the provisions of Technical Approval AT-15-9635/2016,
- the installation instructions prepared by the manufacturer of the panels and provided to customers with each delivery.

2. TECHNICAL CHARACTERISTICS AND REQUIREMENTS

2.1 (Raw) materials

The following (raw) materials are required for the production of Alura heating panels:

- gypsum boards classified as type A according to the PN-EN 520+A1:2012 standard;
- rolled aluminum profiles for the collectors and pipes, made of the EN AW - 6063 aluminum alloy according to the PN-EN 573-3:2014 standard/temper T6 according to the PN-EN 515:1996;
- gypsum and acrylic compound;
- acrylic adhesive;
- paper - aluminum foil laminate,
- R600 refrigerant according to the ISO 817:2014 standard.

2.2 Technical and Performance Characteristics

The required technical and performance characteristics for the Alura heating panel are specified in sections 2.2.1 ÷ 2.2.5.

2.2.1 Shape and Dimensions

The shape and dimensions of the panel (Fig.2) The acceptable dimensional deviations are as follows:

- ± 2 mm for the length dimension,
- ± 1 mm for the width dimension,
- ± 0.06 mm for the thickness dimension.

The dimensional deviations for the aluminum profiles used in the production of the panel meet the requirements set out in the PN-EN 12020:2010 standard.

2.2.2. Thermal Performance

The heating capacity of the Alura heating panels should not be more than $\pm 10\%$ lower or higher than the nominal heating capacity value determined using the formula contained in the PN-EN 442- 2:2015 standard:

$$\Phi = K_M \cdot \Delta T^n \text{ [W]},$$

where

Φ is the heating capacity
 ΔT is the average difference in temperatures, calculated using the following formula:

$$\Delta T = \frac{t_1+t_2}{2} - t_r$$

Registered:
SOFFIO Sp. z o.o.
ul. Zielona 11
43-502 Czechowice-Dziedzice
POLAND

Correspondence address:
SOFFIO Sp. z o.o.
ul. Juliusza Słowackiego 33
43-502 Czechowice-Dziedzice
POLAND

NIP: 6521725602
REGON: 362482429
KRS: 0000575000

where: t_1, t_2 – supply and return temperature,
 t_r - is the ambient temperature in the room
 model constant values, $K_M = 1,83$; $n = 1,21$

The heating capacity determined using the above formula is valid for one off Alura panel
 Energy performance chart $Q = f(\Delta T)$

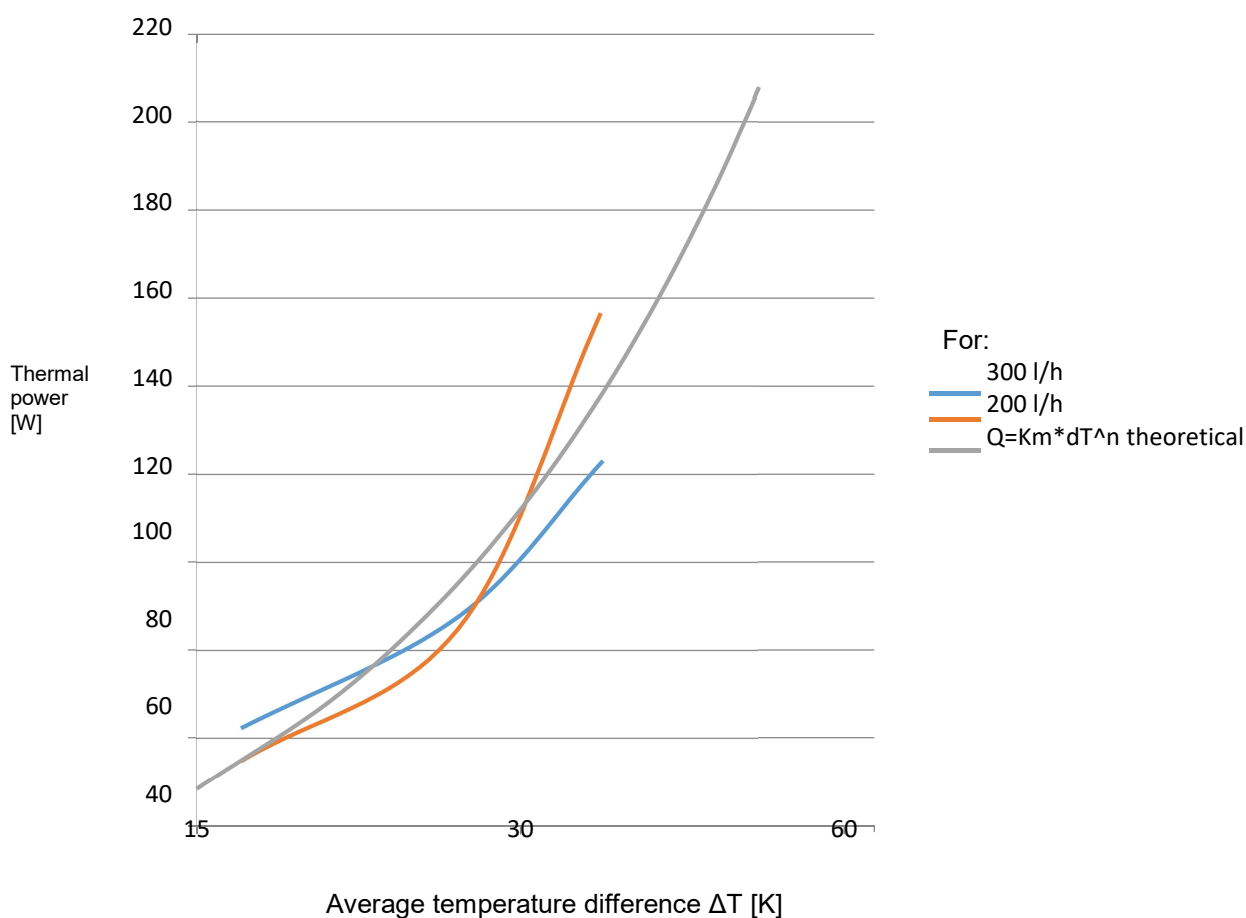

Registered:
SOFFIO Sp. z o.o.
 ul. Zielona 11
 43-502 Czechowice-Dziedzice
 POLAND

Correspondence address:
SOFFIO Sp. z o.o.
 ul. Juliusza Słowackiego 33
 43-502 Czechowice-Dziedzice
 POLAND

NIP: 6521725602
 REGON: 362482429
 KRS: 0000575000

2.2.3 Hydraulic Characteristics

| Flow temperature / return temperature [0°] | Required flow rate [l/min] | Pressure loss [Pa] |
|--|----------------------------|--------------------|
| 38/37 | 0.62 | 500 |
| 45/44 | 0.92 | 800 |
| 55/54 | 1.36 | 1000 |
| 60/59 | 1.59 | 1250 |
| 65/64 | 1.82 | 1600 |
| 75/74 | 2.3 | 2000 |

*The information in the table is given for a single panel.

The log-log plot of pressure drop related to temperature and flow:

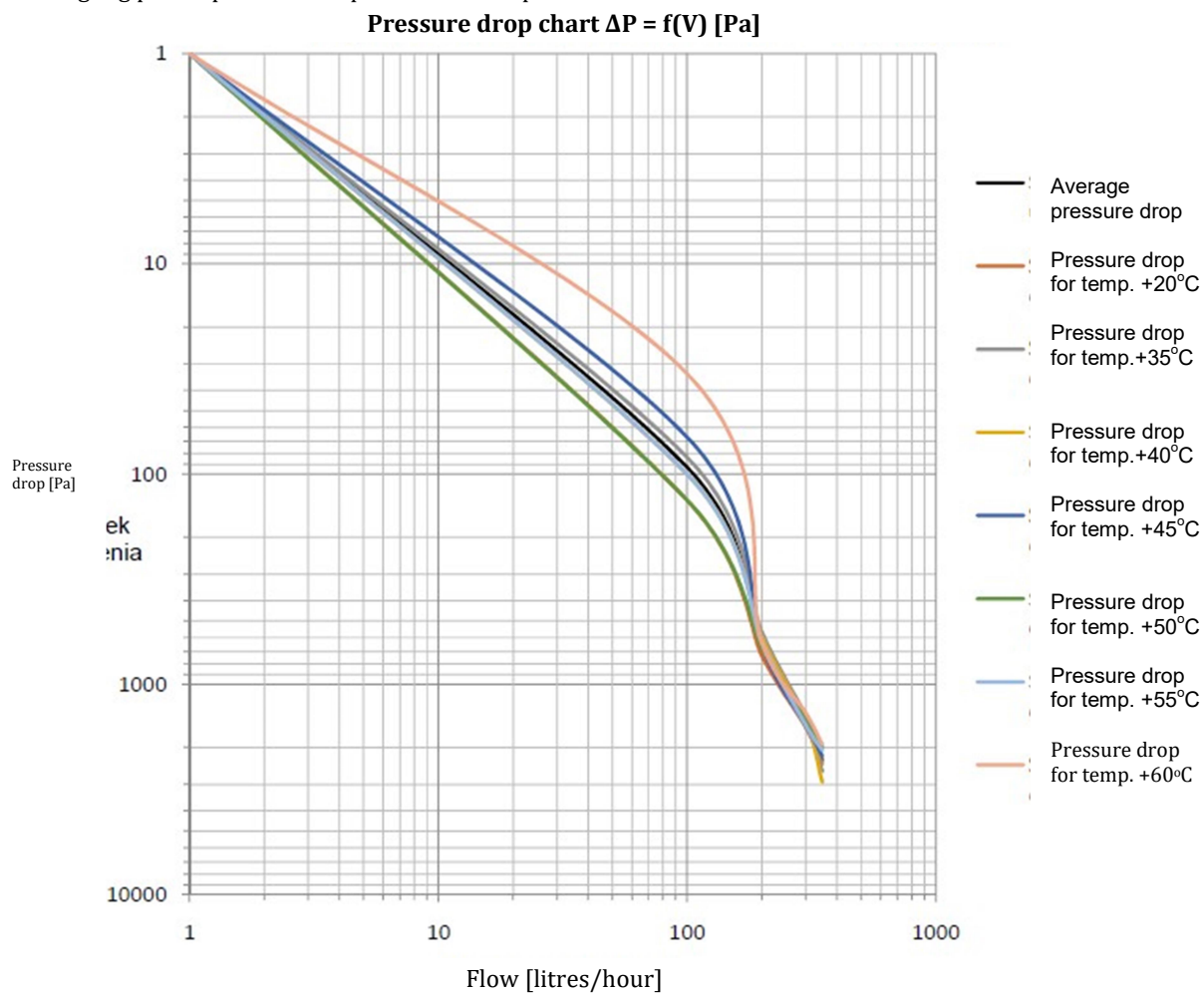

Registered:
SOFFIO Sp. z o.o.
 ul. Zielona 11
 43-502 Czechowice-Dziedzice
 POLAND

Correspondence address:
SOFFIO Sp. z o.o.
 ul. Juliusza Słowackiego 33
 43-502 Czechowice-Dziedzice
 POLAND

NIP: 6521725602
 REGON: 362482429
 KRS: 0000575000

2.2.4 Resistance to Horizontal Loads

The experimentally determined deflections of parts of walls with Alura heating panels caused by the horizontal load values given below do not exceed:

- 25 mm if the horizontal load is distributed evenly and caused by differences in air pressure on both sides of the wall, of 250 Pa;
- 25 mm for a linear load caused by applying horizontal force at a height of 1.20 m from the floor level and with a value of 1.45 kN/m.

2.2.5. Soft Heavy Body Impact and Hard Body Impact Performance

Walls covered with Alura heating panels meet the requirements for soft heavy body Impact and hard body impact performance for use category III according to ETAG 003.

2.2.6. Fire Reaction Classification

The Alura heating panel meets the fire classification criteria set out in the PN-EN 13501-1+A1:2010 for reaction-to-fire class B-s1,d0, classified as fire-proof, non-dripping and non-detachable under the influence of fire) in accordance with the Regulation of the Polish Minister of Infrastructure of 12 April 2002 on the technical requirements for buildings and the location of buildings (Dz.U. (Journal of Laws) No.75/2002, item 690, as amended) and a product which does not spread fire inside buildings, provided that the panel is fixed directly onto or at any distance from reaction-to-fire class A1 or A2 class underlays and elements.

3. PACKING, STORAGE AND TRANSPORT

3.1. Packing

The Alura heating panel requires no packing.

Each panel or each delivery of the panels is accompanied by an information sheet containing, as a minimum, the following details:

- the name and address of the manufacturer,
- the name of the product,
- ITB (Building Research Institute) Technical Approval number (AT-15-9635/2016)
- the date and number of a national declaration of conformity,
- the building industry mark of the product.

The presentation of the building marking of the product is in conformity with the Regulation of the Minister of Infrastructure of 11 August 2004 on concerning the methods of declaring conformity of construction products and marking them with the building industry mark (Dz.U. (Journal of Laws) No.198/2004, item 2041, as amended).

Additionally, if other legislation requires the product to be marked under the Regulation of the Minister of Health of 20 April 2012 on labelling of packaging of dangerous substances and dangerous mixtures

(consolidated text: Dz.U. (Journal of Laws) of 2015, item 450) and Regulation (EC) 1272/2008 of the European Parliament and of the Council on classification, labelling and packaging of substances and mixtures, amending and repealing Directives 67/548/EEC and 1999/45/EC, and amending Regulation (EC) No 1907/2006, or to accompany the product with information on health or life hazards as specified in the product data sheet under Regulation (EC) 1907/2006 (as amended) of the European Parliament and of the Council of 18 December 2006 concerning the Registration, Evaluation, Authorisation and Restriction of Chemicals (REACH), then the product is accompanied by documentation in the required form, containing the marks and information required by law.

3.2. Storage

The Alura heating panel approved by ITB (Building Research Institute) must be stored indoors and protected from weather, damage and/or destruction.

3.3. Transport

Alura wall heating panels should be transported protected against damage or destruction.

4. Documentation

4.1 The product is approved by ITB (Building Research Institute) (Technical Approval number: AT-15-9635/2016)

4.2 The warranty terms and conditions are given in the warranty card for the product.

4.3 Information on the disposal of the product by the distributor

4.4 Installation instructions contained in the Installation Instructions Sheet

4.5 Related standards and documents

| | |
|--------------------|--|
| PN-EN 442-1:2015 | Radiators and Convectors: Part 1: Technical Specifications and Requirements |
| PN-EN 442-2:2015 | Radiators and Convectors. Part 2: Thermal output and test methods |
| ISO 817:2014 | Refrigerants. Designation and safety classification |
| PN-EN 520+A1:2012 | Gypsum plasterboards. Definitions, requirements and test methods ETAG 003 Internal Partition Kits. |
| PN-EN 12020-2:2010 | Aluminium and aluminium alloys. Extruded Precision Profiles of EN AW-6060 and EN AW-6063 Alloys Part 2: Tolerances on Dimensions and Form |
| PN-EN 573-3: | Aluminium and aluminium alloys. Chemical composition and form of wrought products. Part 3: Chemical composition and form of products. |
| PN-EN 515:1996 | Aluminium and aluminium alloys. Wrought products. Temper Designations. |
| PN-EN 14195:2015 | Metal framing components for gypsum board systems. Definitions, requirements and test methods |
| PN-EN 14496:2007 | Gypsum adhesive for plasterboards and composite panels applied in thermal and acoustic insulation systems Definitions, requirements and test methods |
| PN-EN 13279-1:2009 | Gypsum Binders and Gypsum Plasters Part 1: Definitions and requirements |

4.6 Technical drawings

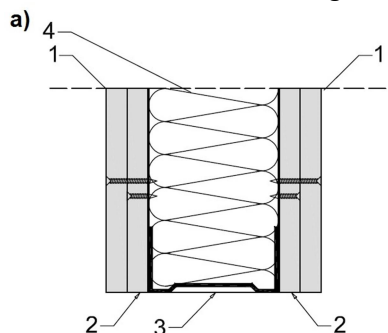

Fixing the panel onto a lightweight framework partition wall

- 1 Alura panel
- 2 gypsum plasterboard
- 3, 4 studwork (vertical and horizontal sections)

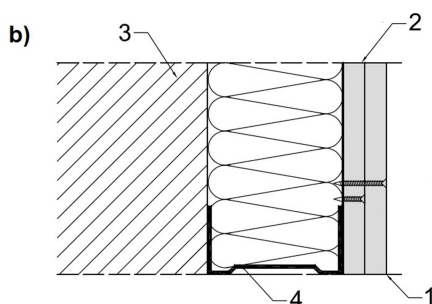

Fixing the panel onto walls made of concrete, reinforced

concrete or bricks, with a single layer of gypsum plasterboards

- 1 Alura panel
- 2 gypsum plasterboard
- 3 a wall made of concrete, reinforced concrete or bricks
- 4 studwork (vertical section)

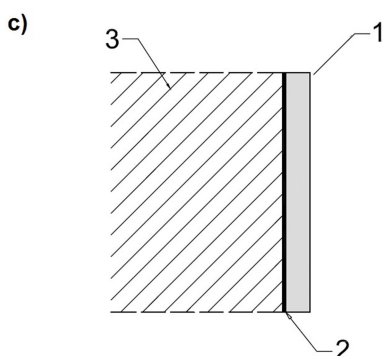

Fixing the panel onto walls made of concrete, reinforced

concrete or bricks using an adhesive

- 1 Alura panel
- 2 an evenly applied layer of adhesive
- a wall made of concrete, reinforced concrete or bricks

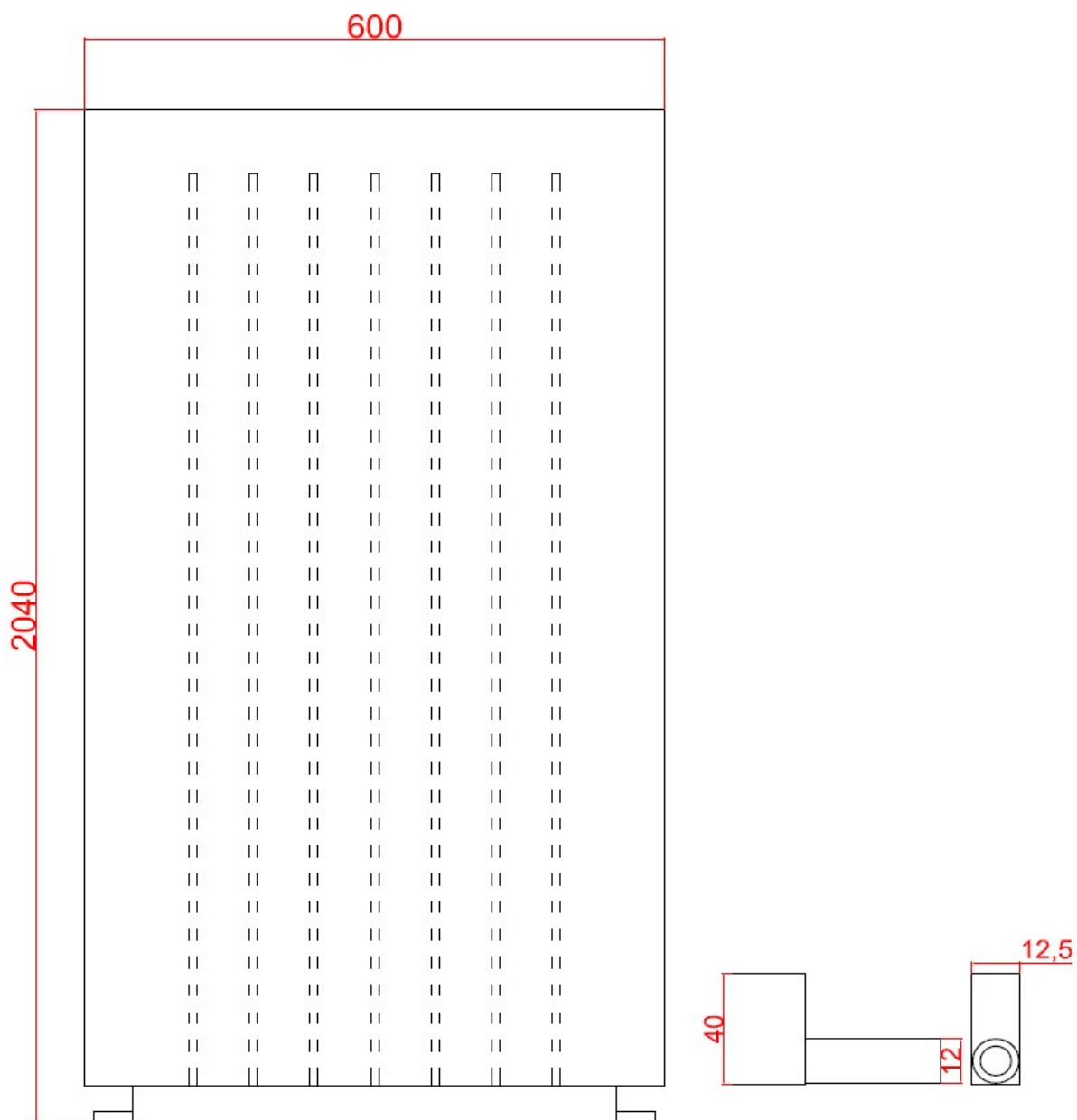

Figure 2 Alura panel dimensions

5. Manufacturer's details

Registered:
SOFFIO Sp. z o.o.
ul. Zielona 11
43-502 Czechowice-Dziedzice
POLAND

Correspondence address:
SOFFIO Sp. z o.o.
ul. Juliusza Słowackiego 33
43-502 Czechowice-Dziedzice
POLAND

NIP: 6521725602
REGON: 362482429
KRS: 0000575000

Alura wall heating panel are manufactured by Soffio Sp. zo.o.
Czechowice-Dziedzice ul. Zielona 11

6. Connecting panels with the use of John Guest couplers

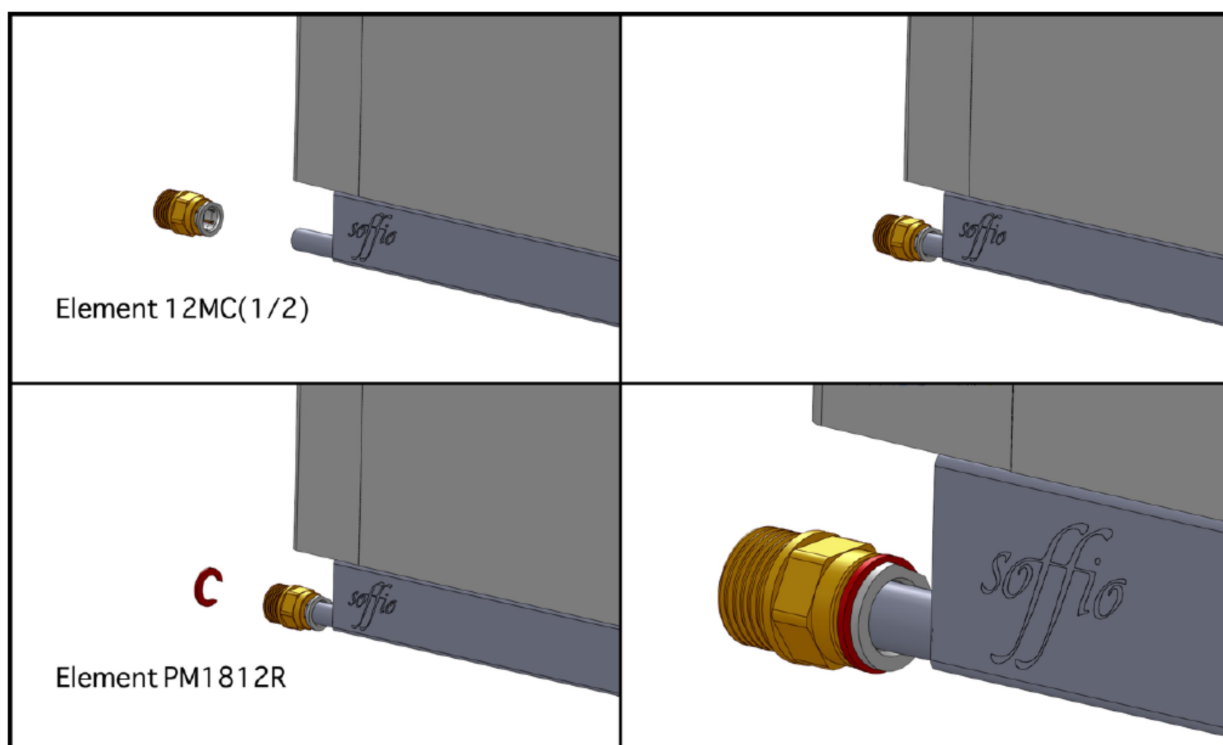

Registered:
SOFFIO Sp. z o.o.
ul. Zielona 11
43-502 Czechowice-Dziedzice
POLAND

Correspondence address:
SOFFIO Sp. z o.o.
ul. Juliusza Słowackiego 33
43-502 Czechowice-Dziedzice
POLAND

NIP: 6521725602
REGON: 362482429
KRS: 0000575000

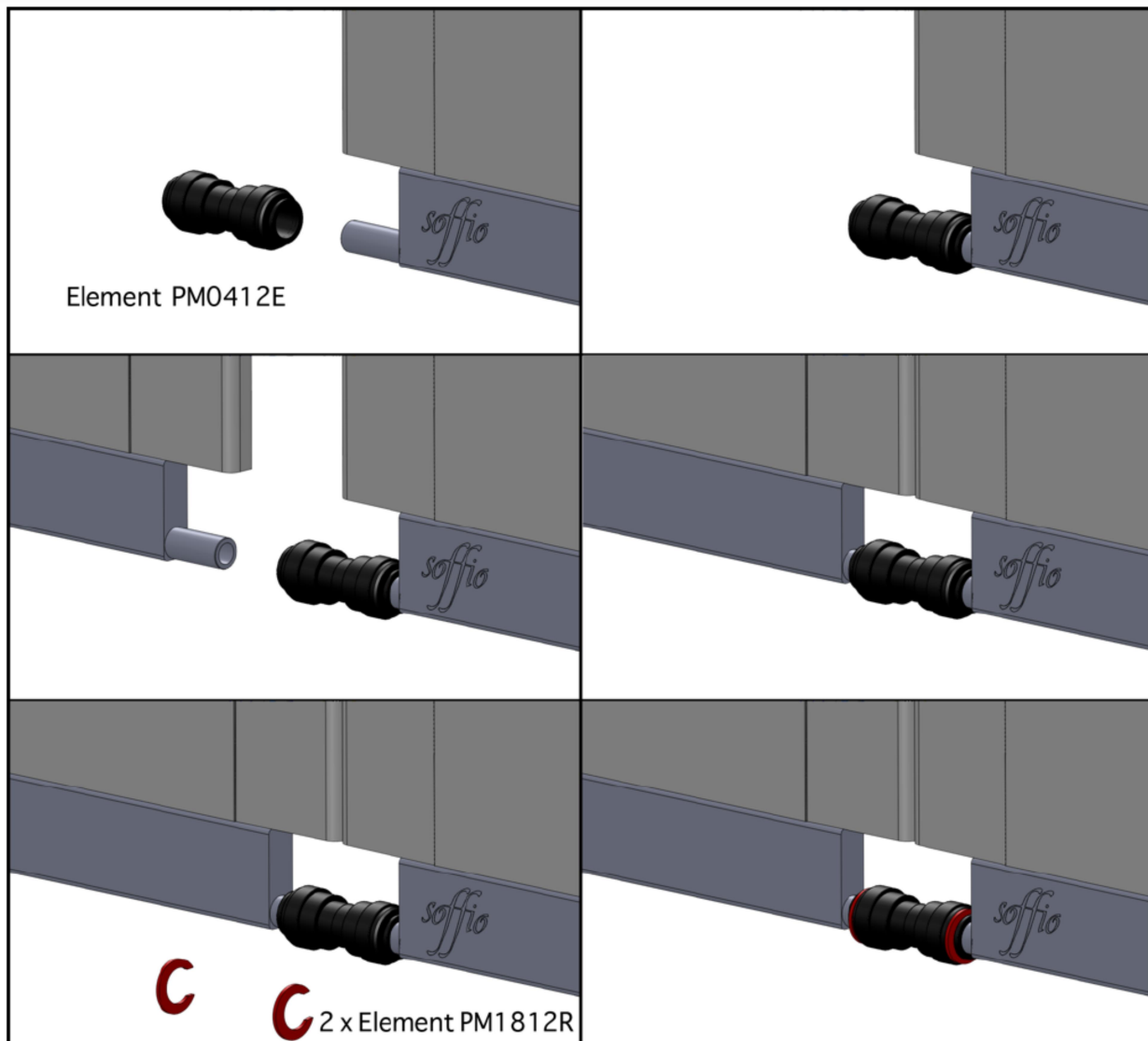

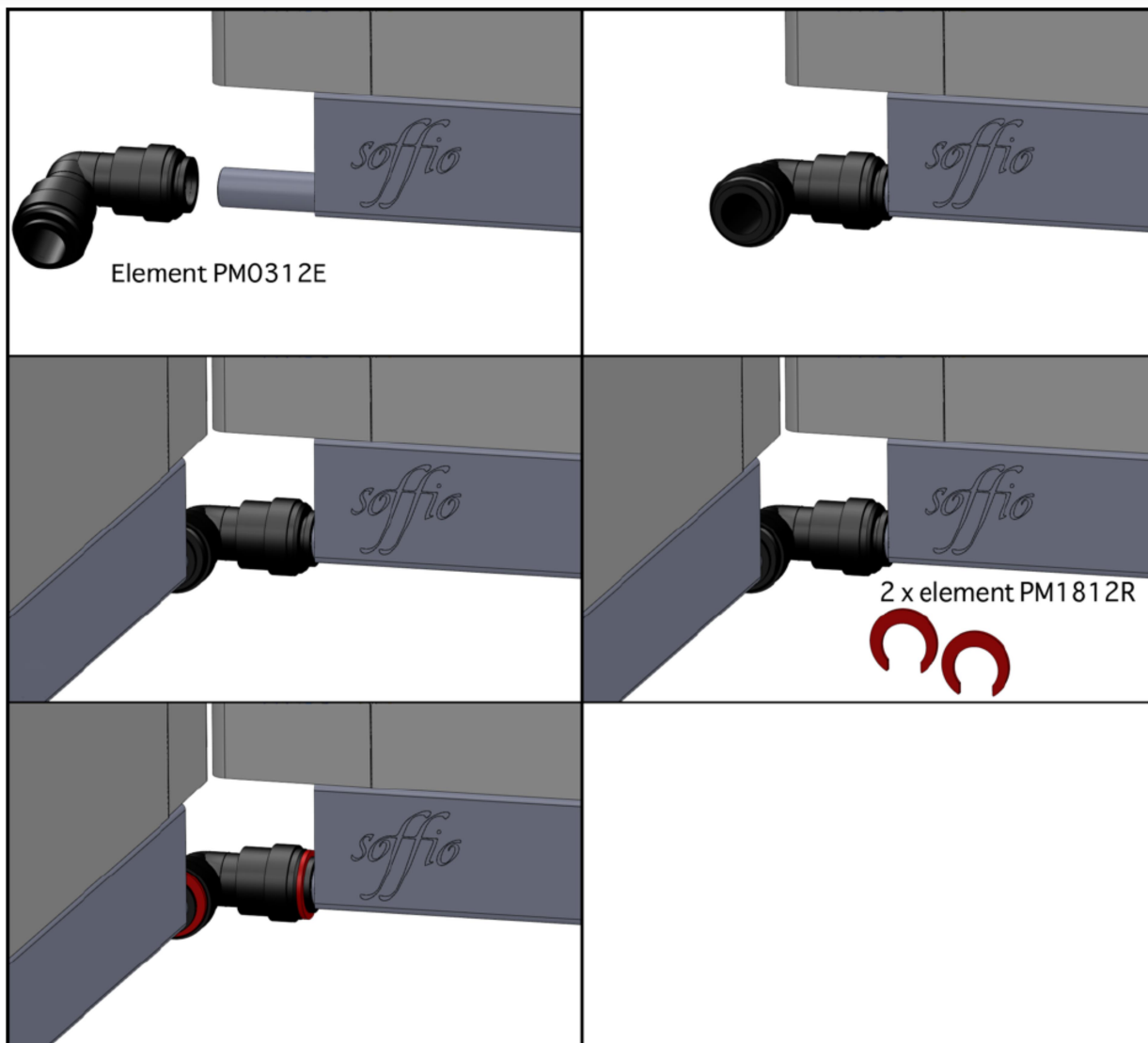

Registered:
SOFFIO Sp. z o.o.
ul. Zielona 11
43-502 Czechowice-Dziedzice
POLAND

Correspondence address:
SOFFIO Sp. z o.o.
ul. Juliusza Słowackiego 33
43-502 Czechowice-Dziedzice
POLAND

NIP: 6521725602
REGON: 362482429
KRS: 0000575000

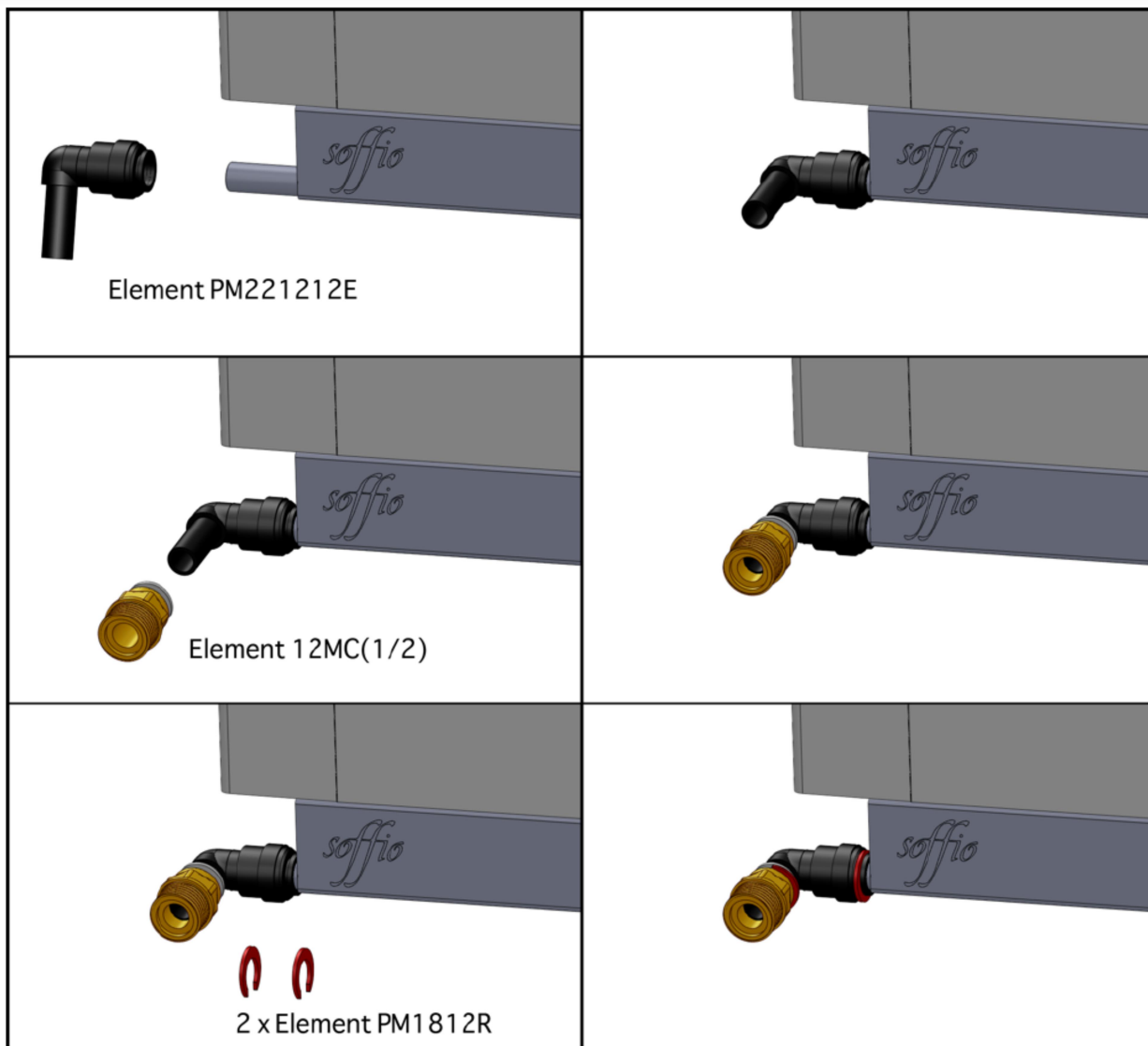

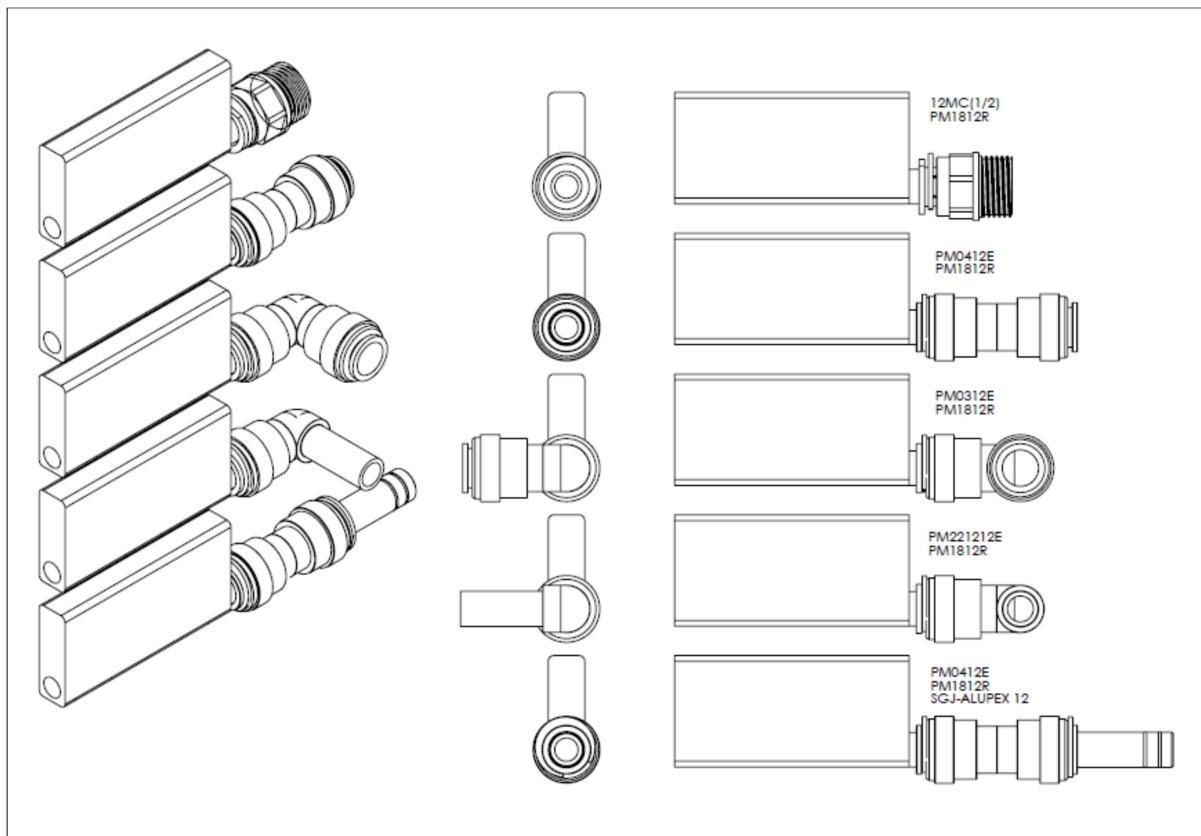

Registered:
SOFFIO Sp. z o.o.
ul. Zielona 11
43-502 Czechowice-Dziedzice
POLAND

Correspondence address:
SOFFIO Sp. z o.o.
ul. Juliusza Słowackiego 33
43-502 Czechowice-Dziedzice
POLAND

NIP: 6521725602
REGON: 362482429
KRS: 0000575000